

WELDER

1st Semester

TRADE PRACTICAL

SECTOR: Fabrication

COMMON FOR THE FOLLOWING TRADES

Welder (GMAW & GTAW) / Welder (Pipe) / Welder (Structural) /
Welder (Welding & Inspection) / Welder (Fabrication & Fitting)



Directorate General of Training

**DIRECTORATE GENERAL OF TRAINING
MINISTRY OF SKILL DEVELOPMENT & ENTREPRENEURSHIP
GOVERNMENT OF INDIA**



**NATIONAL INSTRUCTIONAL
MEDIA INSTITUTE, CHENNAI**

Post Box No. 3142, CTI Campus, Guindy, Chennai - 600 032

Sector : Fabrication

Duration : 1 - Year

**Trades : Welder (GMAW & GTAW), Welder (Pipe), Welder (Structural),
Welder (Welding & Inspection) & Welder (Fabrication & Fitting) - Trade Practical**

Copyright © 2014 National Instructional Media Institute, Chennai

First Edition : February 2018,

Copies : 1,000

Rs.155 /-

All rights reserved.

No part of this publication can be reproduced or transmitted in any form or by any means, electronic or mechanical, including photocopy, recording or any information storage and retrieval system, without permission in writing from the National Instructional Media Institute, Chennai.

Published by:

NATIONAL INSTRUCTIONAL MEDIA INSTITUTE
P. B. No.3142, CTI Campus, Guindy Industrial Estate,
Guindy, Chennai - 600 032.
Phone : 044 - 2250 0248, 2250 0657, 2250 2421
Fax : 91 - 44 - 2250 0791
email : nimi_bsnl@dataone.in
Website: www.nimi.gov.in

FOREWORD

The Government of India has set an ambitious target of imparting skills to 30 crores people, one out of every four Indians, by 2020 to help them secure jobs as part of the National Skills Development Policy. Industrial Training Institutes (ITIs) play a vital role in this process especially in terms of providing skilled manpower. Keeping this in mind, and for providing the current industry relevant skill training to Trainees, ITI syllabus has been recently updated with the help of Mentor Councils comprising of various stakeholder's viz. Industries, Entrepreneurs, Academicians and representatives from ITIs.

The National Instructional Media Institute (NIMI), Chennai, an autonomous body under the Directorate General of Training (DGT), Ministry of Skill Development & Entrepreneurship and is entrusted with developing producing and disseminating Instructional Media Packages (IMPs) required for ITIs and other related institutions.

The institute has now come up with instructional material to suit the revised curriculum for **Welder 1st Semester Trade Practical in Fabrication sector under Semester Pattern**. Relevant exercises of the instructional material is supported with **instructional videos embedded in QR code** which create a platform for an integrated and effective skill learning. I have no doubt that with this added features the trainers and trainees of ITIs, and all stakeholders will derive maximum benefits from these IMPs and that NIMI's effort will go a long way in improving the quality of Vocational training in the country.

The Executive Director & Staff of NIMI and members of Media Development Committee deserve appreciation for their contribution in bringing out this publication.

Jai Hind

ASHEESH SHARMA

Joint Secretary
Ministry of Skill Development & Entrepreneurship,
Government of India.

New Delhi - 110 001

PERFACE

The National Instructional Media Institute (NIMI) was established in 1986 at Chennai by then Directorate General of Employment and Training (D.G.E & T), Ministry of Labour and Employment, (now under Directorate General of Training, Ministry of Skill Development and Entrepreneurship) Government of India, with technical assistance from the Govt. of the Federal Republic of Germany. The prime objective of this institute is to develop and provide instructional materials for various trades as per the prescribed syllabie under the Craftsmen and Apprenticeship Training Schemes.

The instructional materials are created keeping in mind, the main objective of Vocational Training under NCVT/NAC in India, which is to help an individual to master skills to do a job. The instructional materials are generated in the form of Instructional Media Packages (IMPs). An IMP consists of Theory book, Practical book, Test and Assignment book, Instructor Guide, Audio Visual Aid (Wall charts and Transparencies) and other support materials.

The trade practical book consists of series of exercises to be completed by the trainees in their workshop. These exercises are designed to ensure that all the skills in the prescribed syllabus are covered. The trade theory book provides related theoretical knowledge required to enable the trainee to do a job. The test and assignments will enable the instructor to give assignments for the evaluation of the performance of a trainee. The wall charts and transparencies are unique, as they not only help the instructor to effectively present a topic but also help him to assess the trainee's understanding. The instructor guide enables the instructor to plan his schedule of instruction, plan the raw material requirements, day to day lessons and demonstrations.

In order to perform the skills in a productive manner instructional videos are embedded in QR code of the exercise in this instructional material so as to integrate the skill learning with the procedural practical steps given in the exercise. The instructional videos will improve the quality of standard on practical training and will motivate the trainees to focus and perform the skill seamlessly.

IMPs also deals with the complex skills required to be developed for an effective team work. Necessary care has also been taken to include important skill areas of allied trade as prescribed in the syllabus.

The availability of a complete Instructional Media Package in an institute helps both the trainer and management to impart an effective training.

The IMPs are the outcome of collective efforts of the staff members of NIMI and the members of the Media Development Committees specially drawn from Public and Private sector industries, various training institutes under the Directorate General of Training (DGT), Government and Private ITIs.

NIMI would like to take this opportunity to convey sincere thanks to the Directors of Employment & Training of various State Governments, Training Departments of Industries both in the Public and Private sectors, Officers of DGT and DGT field institutes, proof readers, individual media developers and coordinators, but for whose active support NIMI would not have been able to bring out this materials.

Chennai - 600 032

**R. P. DHINGRA
EXECUTIVE DIRECTOR**

CONTENTS

Exercise No.	Title of the exercise	Page No.
	Module 1 : Fitting and Sheet Metal Working	
1.1.01	Marking out on M.S plate or flat	1
1.1.02	Edge chipping	4
1.1.03	Cutting M.S. sheet by chisel	7
1.1.04	Hack sawing	9
1.1.05	Filing square to dimensions	13
1.1.06	Marking and Making a hollow cylinder	15
1.1.07	Taper tray	19
	Module 2 : Oxy-Acetylene gas cutting	
1.2.01	Induction Training	23
1.2.02	Oxy-Acetylene hand cutting on MS plate 10mm (straight and bevel cut) (with QR Code for related videos) *	29
1.2.03	Oxy-Acetylene machine cutting (straight, bevel, circle and profile)	34
	Module 3 : Oxy-Acetylene gas welding	
1.3.01	Fusion run without and with filler rod on MS sheet 3.0mm in flat position	37
1.3.02	Edge joint on MS sheet 2mm in flat position	43
1.3.03	Butt weld square butt joint on MS sheet 2.0mm in flat position (with QR Code for related videos) *	45
1.3.04	Fillet weld - open corner joint on M.S sheet 2.0mm in flat position	48
1.3.05	Fillet weld - Lap joint on MS sheet 2.0mm in flat position	51
1.3.06	Fillet weld 'T' joint on M.S sheet 2.0mm in flat position	54
1.3.07	Butt weld - square butt joint on MS sheet 2.0mm in horizontal position	57
1.3.08	Fillet weld - lap joint on MS sheet 2.0mm in horizontal position	59
1.3.09	Fusion run with filler rod on MS sheet 2.0mm in vertical position	61
1.3.10	Butt weld square butt joint on MS sheet 2.0mm in vertical position	64
1.3.11	Fillet weld Tee joint on MS sheet 2.0mm in vertical position	66
1.3.12	Structural pipe welding butt joint on MS pipe ϕ 50mm x 3mm wall thickness in 1G (rolling) position	69

Exercise No.	Title of the exercise	Page No.
1.3.13	Structural pipe welding elbow joint on MS pipe ϕ 50mmx3mm Wall thickness in flat position	72
1.3.14	Structural pipe welding 90° Tee joint on MS pipe 50mm dia. x 3mm Wall thickness in flat position	74
1.3.15	Square Butt and Lap joint on M.S. sheet 2mm thick by brazing	76
1.3.16	Pipe welding 45° angle joint on M.S. Pipe ϕ 50 x 3mm wall thickness by OAW	79
1.3.17	Butt weld - Square butt joint on aluminium sheet 3mm thick in flat position	82
1.3.18	Square butt joint on stainless steel sheet 2.0mm thick in flat position	85
1.3.19	Square butt joint on brass sheet 2mm thick in flat position	87
1.3.20	Bronze welding of cast iron. Single "V" butt joint on cast iron plate 6mm thick	89
Module 4 : Shielded metal arc welding		
1.4.01	Induction training	92
1.4.02	Straight line beads on MS plate 10mm thick in flat position	97
1.4.03	Weaved bead on MS plate 10mm thick in flat position	101
1.4.04	Fillet weld "T" joint on MS plate 10mm thick in flat position	105
1.4.05	Fillet weld lap joint on MS plate 10mm thick in flat position (with QR Code for related videos) *	108
1.4.06	Fillet weld open corner joint on MS plate 10mm thick in flat position	111
1.4.07	Single "V" butt joint on MS plate 12mm thick in flat position(1G) (with QR Code for related videos) *	115
1.4.08	Straight lines beads on MS plate 10mm thick in horizontal position	118
1.4.09	Fillet weld - 'T' joint on MS plate 10mm thick in horizontal position (with QR Code for related videos) *	120
1.4.10	Fillet weld Lap joint MS plate 10mm position horizontal by SMAW	123
1.4.11	Single "V" butt joint on MS plate 12mm thick in horizontal position (2G)	125
1.4.12	Weaved beads on MS plate 10mm thick in vertical position	128
1.4.13	Fillet weld - "T" joint on MS plate 10mm thick in vertical position	133
1.4.14	Fillet weld - lap joint on MS plate 10mm thick in vertical position	136
1.4.15	Fillet weld - open corner joint on MS plate 10mm thick in vertical position	139
1.4.16	Single "V" butt joint on MS plate 12mm thick in vertical position (3G)	142

Exercise No.	Title of the exercise	Page No.
1.4.17	Straight line beads on MS plate 10mm thick in over head position	145
1.4.18	Fillet weld - "T" joint on MS plate 10mm thick in over head position	148
1.4.19	Fillet weld - Lap joint on MS plate 10mm thick in over head position	151
1.4.20	Single "V" butt joint on MS plate 10mm thick in over head position (4G)	153
1.4.21	Structural pipe welding, Pipe flange joint on MS pipe Ø50mm x 6mm wall thickness and MS plate 6mm thick in flat position	156
1.4.22	Structural pipe welding butt joint on MS pipe Ø50mmx6mm wall thickness in 1G (rolled) position	160
1.4.23	Square butt joint on stainless steel sheet 2mm thick in flat position	163
1.4.24	Single "V" butt joint on cast iron plate 6mm thick in flat position	165
Module 5 : Arc Gouging		
1.5.01	Arc gouging with gouging electrode MS plate 10mm thick in flat position	168
<div style="border: 1px solid black; border-radius: 10px; padding: 10px; background-color: #e0e0e0;"> <p>* Steps to download and scan a Quick Response (QR) code</p> <ul style="list-style-type: none"> • Download QR Code app on your phone • Run app and scan the QR code • Your smart phone will read the code and navigate to the destination </div>		

Marking out on M.S plate or flat

Objectives: At the end of this exercise you shall be able to

- use the steel rule, scribe, dot punch and hammer
- apply marking media on metallic surface
- scribe straight and parallel lines on the surface of the plate or flat
- use a hammer and a dot punch to make punch marks on the scribed lines.

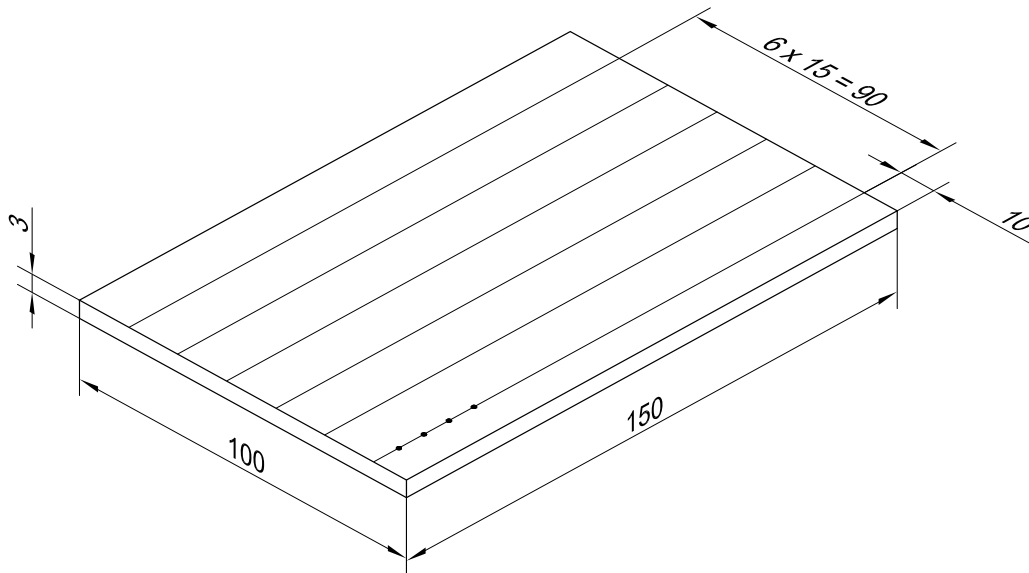

1	100 ISF 3 - 150		Fe 310			1.1.01
NO.OFF	STOCK SIZE	SEMI PRODUCT	MATERIAL	PROJECT NO.	PART NO.	EX. NO.
SCALE NTS	MARKING OUT ON M.S. FLAT / PLATE				TOLERANCE ± 1	TIME 5h
					CODE NO. WL1101E1	

Job Sequence

- Check the size of the given MS sheet as per drawing.
- Apply copper sulphate/chalk powder solution and allow it to dry.
- Keep the plate or flat on the work bench and mark points A, B, C, D, E & F and A_1 , B_1 , C_1 , D_1 , E_1 & F_1 as per dimensions given on the job drawing.
- Draw the 6 lines joining the points A and A_1 , B and B_1 , etc upto F and F_1 .
- Check the marked lines for the correctness and parallalism visually.
- Using a dot punch and a hammer make punch marks on all the lines with a pitch of 4mm.

Skill Sequence

The marking media, copper sulphate or chalk powder solution, is applied on the job surface and dried so that the lines scribed on it will be clearly visible.

Apply the marking media uniformly with a 15mm painting brush.

Using steel rule and scriber point mark points A, B, C, D, E & F from the 150mm long edge of job at 10, 25, 40, 55, 70

and 85mm distances. Similarly mark points A_1 , B_1 , C_1 , D_1 , E_1 & F_1 (Fig 1) The edge of the steel rule may have damaged. To avoid wrong measurement coincide or set the 1st or 2nd cm graduation mark of the steel rule against the 150mm long edge of the job for taking measurements and marking of points A to F and A_1 to F_1 . Ensure that there is no parallax error (observation error) while using the scale to mark the points A to F and A_1 to F_1 (Fig 2)

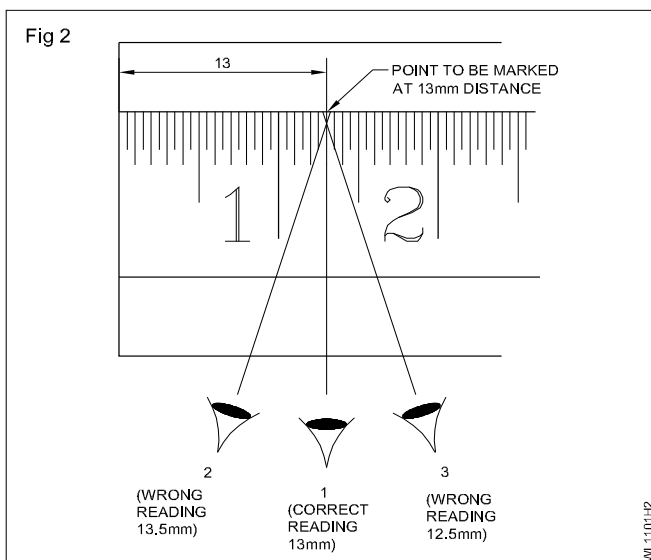
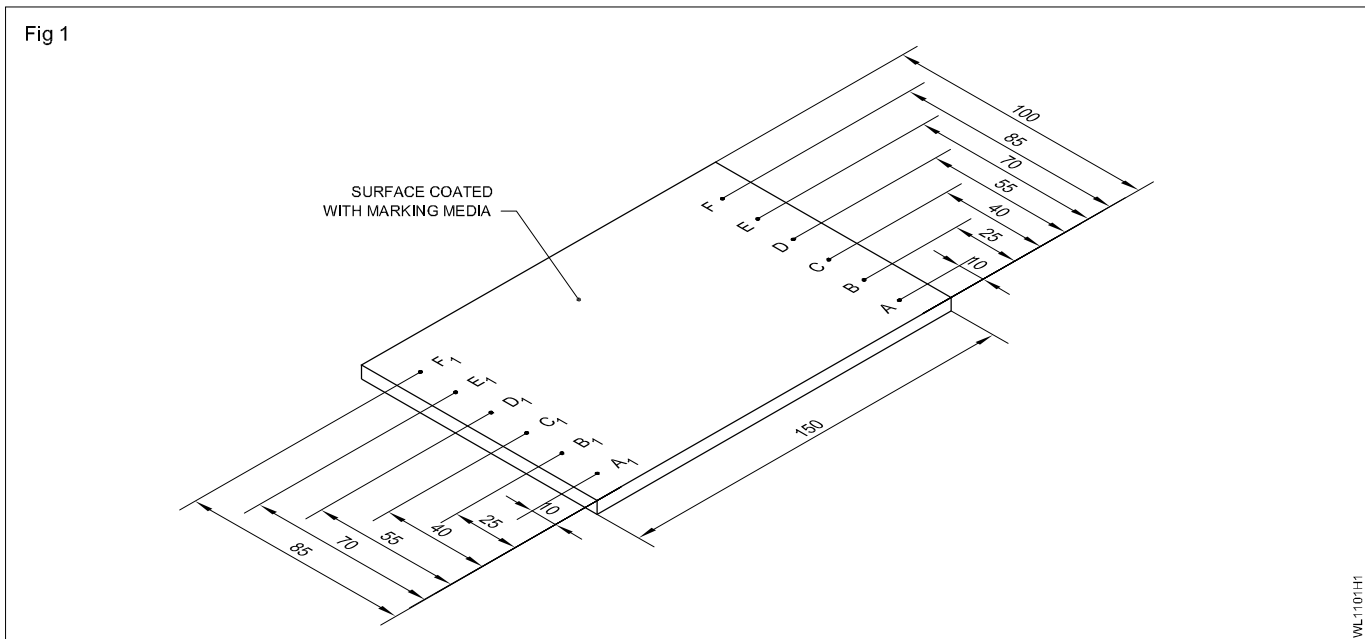

Using the steel rule and scriber, draw the lines AA_1 , BB_1 , CC_1 , DD_1 , EE_1 & FF_1 .

Incline the scriber in the direction of stroke and draw towards you (Fig 3)

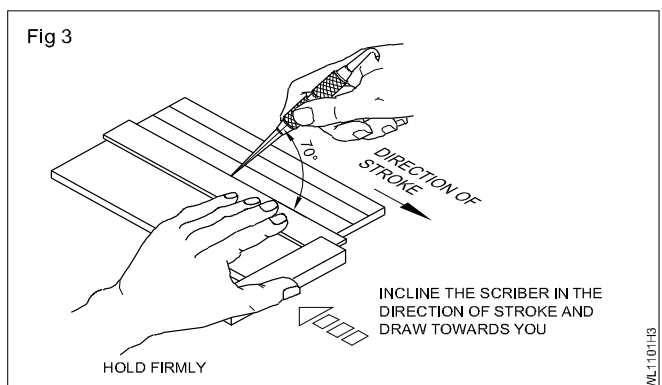

Using the dot punch and the hammer, punch small dots on the 6 lines. (Fig 4 and Fig 5) While hammering hold at the extreme end of the handle.

Maintain a pitch of 4mm approximately between the dots. Pitch is the distance between two consecutive dots.

Check whether the lines are straight and parallel using steel rule and the punch marks are clear and visible.

